

TYPICAL APPLICATIONS

Spraying applications. For other applications, contact SHURflo.

PUMP

Type	3 Chamber Diaphragm
Ports	1/2"-14 NPSM-Male
Liquid	130 °F [54 °C] Max
Prime	9 feet [2.7 M]
Inlet PSI	30 PSI [2.1 Bar] Max
Run Dry	Yes

ELECTRICAL

Motor	24 VDC Permanent Magnet, Intermittent Duty
Protection	Thermal Overload, Automatic Restart
Leads	16 AWG, 16" [40 cm] Red +, 13" [33 cm] Black -
Fuse	10 Amp Time Delay Recommended
Control	Bypass 60 PSI max. Pressure

MATERIALS

Housing	Polypropylene
Valves	EPDM
Diaphragm	Santoprene
Hardware	Zinc Plated Steel

WARRANTY

1 Year Limited Warranty
See SB-1041 For Full Warranty Details

SHIPPING

Net Weight (Boxed)	5 Lb [2.3Kg] each
Carton Weight	12 each, 52 Lb [24 Kg]
Carton Size	24"L x 18"W x 11"H [61cm x 46cm x 28cm]

DIMENSIONS:

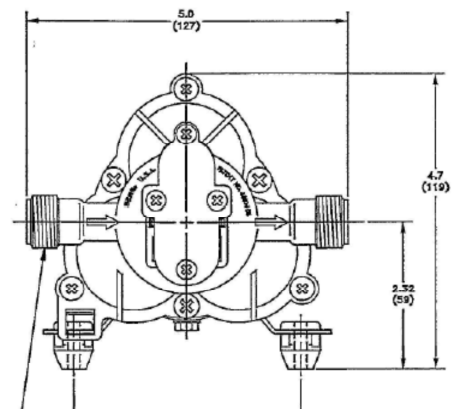
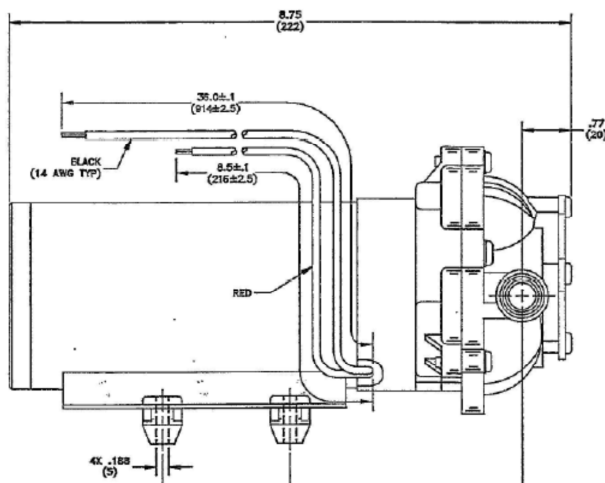

Typical Performance @ 24 VDC

TEMPERATURE RISE

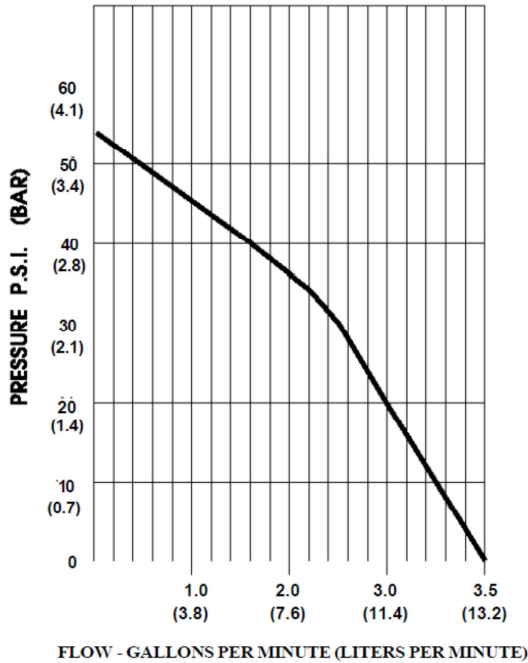
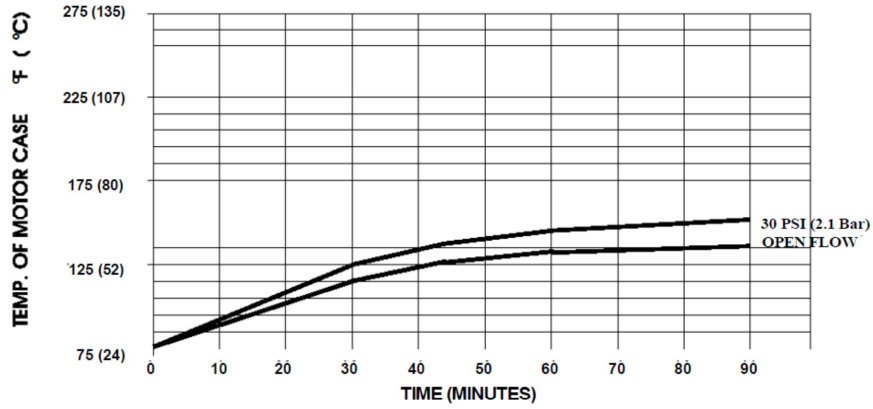

PRESSURE (PSI)	FLOW (GPM/LIT)	Current (AMPS)	Voltage (VOLTS)
OPEN	3.5/13.2	2.8	24 VDC
10	3.4/12.9	4.0	"
20	3.2/12.1	4.8	"
30	2.3/8.7	5.5	"
40	1.6/6.0	5.8	"
50	0.6/2.3	6.5	"



* ISO Registered Facility

SHURflo reserves the right to update specifications, prices, or make substitutions.