



PRODUCT DATA SHEET MODEL: 8000-541-250

SPECIFICATIONS:

Model Number: 8000-541-250

Pump: Positive displacement 3 chamber diaphragm pump

Self-Priming up to 11 feet

Maximum liquid Temperature: 130 F

Maximum inlet pressure 30 PSI

Run dry: Yes

Material of construction:

Plastics: Polypropylene, Upper housing with 3/8"-18 NPT Female ports

Valves: Viton

Diaphragm: Santoprene 2.0 degree cam

Control: Bypass max. 45 PSI

Electrical: 12 VDC Permanent Magnet Brush Motor

Duty cycle: intermittent

DIMENSIONS:

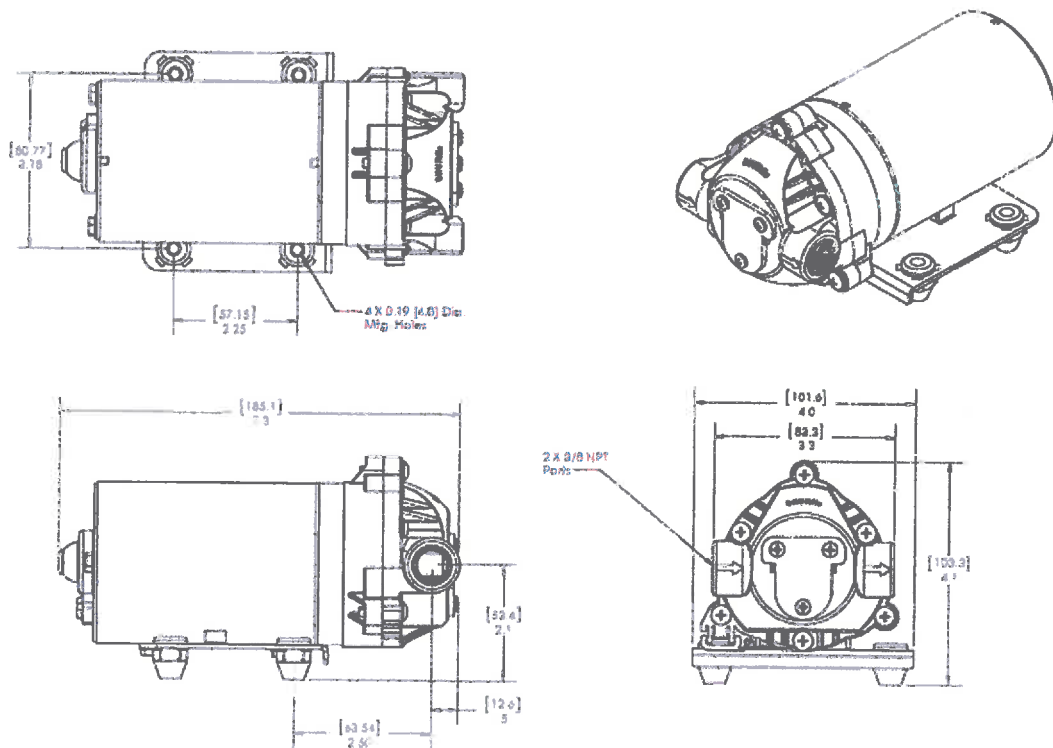

PENTAIR WATER BELGIUM bvba

Industriepark Wolfstee, Toekomstlaan 30, B-2200 Herentals, Belgium

TEL: +32-14-283 500 FAX: +32-14-283 505 email: shurflo@pentair.com

©03102016



PRODUCT DATA SHEET Model 8000-541-250

TYPICAL PERFORMANCE:

Pressure	Flow	Current	Voltage
0 psi	3,4 lpm	3,0 A	12VDC
10 psi	3.3 lpm	3,4 A	"
20 psi	2,9 lpm	4,0 A	"
30 psi	2,4 lpm	4,7 A	"
40 psi	1,6 lpm	5,2 A	"
50 psi	0.4 lpm	5,5 A	"